

Navigation & Multimedia System Owner's Manual

Supplement for
Apple CarPlay and Android Auto



TOYOTA MOTOR CORPORATION AUSTRALIA LIMITED

A.B.N. 64 009 686 097

© 2019 TOYOTA MOTOR CORPORATION AUSTRALIA LIMITED

All rights reserved. This material may not be reproduced or copied, in whole or part, without the written permission of Toyota Motor Corporation Australia Limited, 155 Bertie Street, Port Melbourne, Victoria

Quick guide	<ul style="list-style-type: none"> • Basic system overview • Giving guidance for the route quickly 	1
Basic function	<ul style="list-style-type: none"> • Information to be read before operation • Setting initial settings before operation • Connecting the Bluetooth® device 	2
Navigation system*	<ul style="list-style-type: none"> • Operating the map screen • Searching the map • Activating route guidance 	3
Audio/visual system	<ul style="list-style-type: none"> • Listening to the radio • Enjoying music and video 	4
Speech command system	<ul style="list-style-type: none"> • Operating the speech command system 	5
Peripheral monitoring system*	<ul style="list-style-type: none"> • Checking the situation around the vehicle 	6
Phone	<ul style="list-style-type: none"> • Operating the phone (Hands-free system for cellular phones) 	7
Toyota App Suite	<ul style="list-style-type: none"> • Operating the Toyota App Suite 	8
Software update terms of use		
Index	<ul style="list-style-type: none"> • Search alphabetically 	

*: For sections shown light shaded, refer to the Navigation & Multimedia System Owner's Manual

Quick guide

1-1. Basic function 6
Buttons overview 6
“Menu” screen 8

Basic function

2-1. Basic information before operation 10
Touch screen 10
Linking multi-information display and the system 11
2-2. Connectivity settings 12
Registering/Connecting a Bluetooth® device 12
2-3. Apple CarPlay/Android Auto . . 13
Apple CarPlay/Android Auto 13
2-4. Other settings 20
General settings 20

Audio/visual system

4-1. Basic operation 22
Quick reference 22
4-2. Media operation 24
USB memory 24
iPod/iPhone (Apple CarPlay) 25
Android Auto 26
Bluetooth audio 27
4-3. Audio/visual remote controls . 28
Steering switches 28

Speech command system

5-1. Speech command system operation 30
Speech command system 30
Command list 31

Phone

7-1. Phone operation (Hands-free system for cellular phones) . . 34
Phone basics 34

Toyota App Suite

8-1. Toyota App Suite overview . . . 36
Toyota App Suite service 36
8-2. Toyota App Suite operation . . 38
Toyota App Suite 38
Toyota App Suite settings 42
8-3. Setup 42
Toyota App Suite settings 42

Software update terms of use

Software update terms of use . . . 44

Alphabetical index

Alphabetical index 48

Introduction

This Navigation & Multimedia System Owner's Manual supplement is to be used in conjunction with the Navigation & Multimedia System Owner's Manual supplied with your vehicle. It explains the operation and features that may differ from the manual provided with the vehicle.

Please read this manual carefully to ensure proper use.

The screens shown in this manual may differ from the actual screen of the system depending on your vehicle, the availability of functions, and map data available at the time this manual was produced.

The screens in this manual will also differ if the screen theme settings have been changed. In some situations when changing between screens, it may take longer than normal for the screen to change, the screen may be blank momentarily or noise may be displayed.

Please be aware that the content of this manual may be different from this system in some cases, such as when the system's software is updated.

The company names and product names appearing on this manual are the trademarks and registered trademarks of their respective companies.

Buttons overview 6
 Operations of each part 6



“Menu” screen 8
 “Menu” screen operation 8

Buttons overview

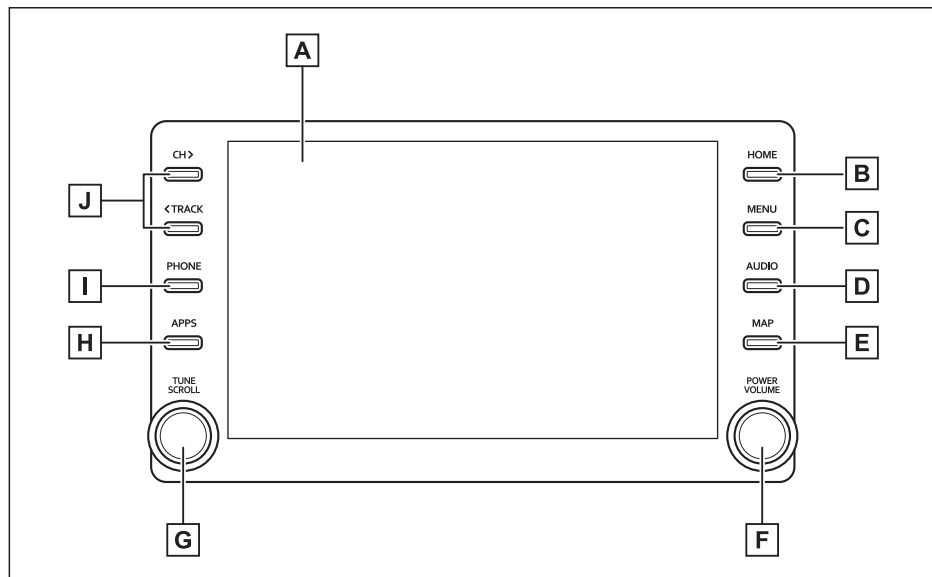
Operations of each part



A	By touching the screen with your finger, you can control the selected functions. (→P.10)
B	Press to access the home screen. (→Section 2-1 in the Navigation & Multimedia System Owner's Manual)
C	Press to display the "Menu" screen. (→P.8)
D	Press to access the audio/visual system. (→P.22)
E	Press to display the map screen and repeat a voice guidance. (→Section 3-1 in the Navigation & Multimedia System Owner's Manual) <ul style="list-style-type: none"> When an Apple CarPlay/Android Auto connection is established, press to display the Maps application screen.
F	Press to turn the audio/visual system on and off, and turn it to adjust the volume. Press and hold to restart the system. (→Section 2-1 in the Navigation & Multimedia System Owner's Manual)
G	Turn to change the radio station or skip to the next or previous track/file. (→Section 4-2 in the Navigation & Multimedia System Owner's Manual)
H	Press to display the application screen.* (→P.38)

	Press to access the Bluetooth® hands-free system. (→Section 7-1 in the Navigation & Multimedia System Owner's Manual) <ul style="list-style-type: none">• When an Apple CarPlay connection is established, press to display the phone application screen.
	Press to seek up or down for a radio station or to access a desired track/file. (→Section 4-2 in the Navigation & Multimedia System Owner's Manual)

*: When an Apple CarPlay/Android Auto connection is established, this function will be unavailable.

“Menu” screen

“Menu” screen operation

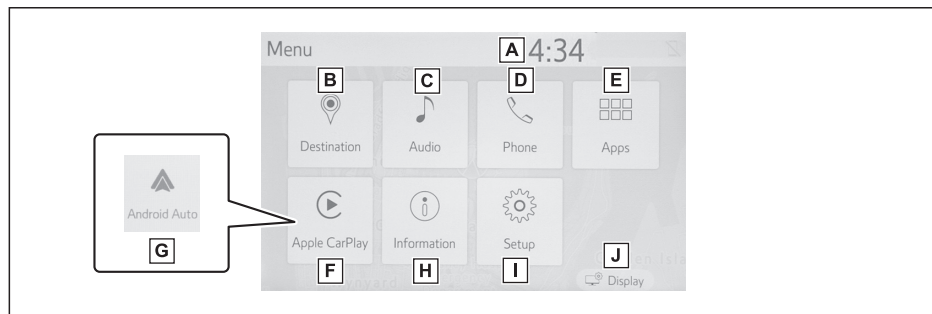

A	Displays the clock. Select to display the clock settings screen. (→Section 2-4 in the Navigation & Multimedia System Owner's Manual)
B	Select to display the destination screen. (→Section 3-2 in the Navigation & Multimedia System Owner's Manual)
C	Select to display the audio control screen. (→P.22)
D	Select to display the hands-free operation screen. (→Section 7-1 in the Navigation & Multimedia System Owner's Manual) <ul style="list-style-type: none"> When an Apple CarPlay connection is established, select to display the phone application screen.
E	Select to display the application screen.* (→P.38)
F	When an Apple CarPlay connection is established, select to display the home screen of Apple CarPlay. (→P.13)
G	When an Android Auto connection is established, select to display the home screen of Android Auto. (→P.14)
H	Select to display the “information” screen. (→Section 1-1 in the Navigation & Multimedia System Owner's Manual)
I	Select to display the “Setup” screen. (→Section 1-1 in the Navigation & Multimedia System Owner's Manual)
J	Select to adjust the contrast and brightness of the screens, etc. (→Section 2-1 in the Navigation & Multimedia System Owner's Manual)



*: When an Apple CarPlay/Android Auto connection is established, this function will be unavailable.

- Touch screen 10**
 - Touch screen gestures 10
- Linking multi-information display and the system. 11**
- Registering/Connecting a Bluetooth® device 12**
- Apple CarPlay/Android Auto . . . 13**
 - Establishing an Apple CarPlay connection 13
 - Establishing an Android Auto connection 14
 - Troubleshooting 17
- General settings 20**
 - Displaying the general settings screen 20
 - Projection settings 20

Touch screen

Touch screen gestures

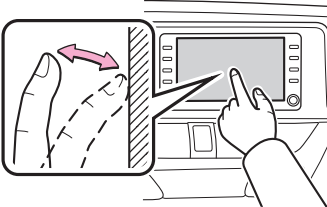
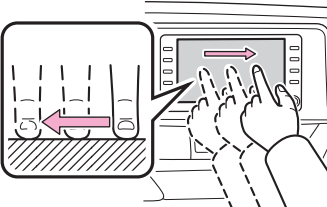
Operations are performed by touching the touch screen directly with your finger.

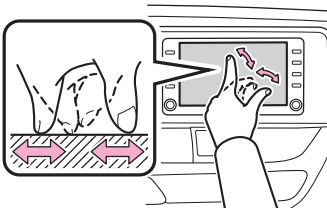
Operation method	Outline	Main issue
	<ul style="list-style-type: none"> • Touch <p>Quickly touch and release once.</p>	<ul style="list-style-type: none"> • Selecting an item on the screen
	<ul style="list-style-type: none"> • Drag^{*1} <p>Touch the screen with your finger, and move the screen to the desired position.</p>	<ul style="list-style-type: none"> • Scrolling the lists • Scrolling the map screen • Moving an item on a list
	<ul style="list-style-type: none"> • Flick^{*1} <p>Quickly move the screen by flicking with your finger.</p>	<ul style="list-style-type: none"> • Scrolling the main screen page • Scrolling the map screen
	<ul style="list-style-type: none"> • Pinch in/Pinch out^{*2} <p>Slide fingers toward each other or apart on the screen.</p>	<ul style="list-style-type: none"> • Changing the scale of the map

*1: The above operations may not be performed on all screens.

*2: The Apple CarPlay Maps application is not compatible with pinch multi-touch gestures.

Linking multi-information display and the system

The following functions of the system are linked with the multi-information display in the instrument cluster:

- Navigation
- Audio
- Phone*
- etc.

These functions can be operated using the multi-information display control switches on the steering wheel. For details, refer to the Owner's Manual.

*: When an Apple CarPlay connection is established, this function will be unavailable.

Registering/Connecting a Bluetooth® device

To use the hands-free system, it is necessary to register a Bluetooth® phone with the system.

Once the phone has been registered, it is possible to use the hands-free system.

This operation cannot be performed while driving.

When an Apple CarPlay connection is established, Bluetooth® functions of the system will become unavailable and any connected Bluetooth® devices will be disconnected.

When connecting to Android Auto, a Bluetooth® connection will be made automatically.

When an Android Auto connection is established, some Bluetooth® functions other than hands-free system cannot be used.

Apple CarPlay/Android Auto

Apple CarPlay/Android Auto allows some applications, such as Map, Phone, and Music, to be used on the system.

When an Apple CarPlay/Android Auto connection is established, Apple CarPlay/Android Auto compatible applications will be displayed on the system display.

- Compatible devices

Apple iPhone (iOS Ver. 11 or later) that supports Apple CarPlay.

For details, refer to <https://www.apple.com/ios/carplay/>

Android devices with Android OS Ver. 5.0 or higher which support Android Auto and have the Android Auto application installed.

For details, refer to <https://www.android.com/auto/>

Establishing an Apple CarPlay connection

1. Enable Siri on the device to be connected.
2. Connect the device to the USB port. (→Section 4-1 in the Navigation & Multimedia System Owner's Manual)
- Use a high quality USB cable that is less than 1.6 metres in length.
3. Select "Always enable" or "Enable once".



- If "Do not enable" is selected, an Apple CarPlay connection will not be established.
In this case, the device can be operated as a normal Apple device, such as an iPod.
Apple CarPlay will remain off until "Apple CarPlay" of "Projection settings" on the general settings screen is turned on. (→P.20)
 - Depending on the device connected, it may take approximately 3 to 6 seconds before the system returns to previous screen.
 - The screen may change to step **6** depending on the system.
4. Press the "MENU" button.

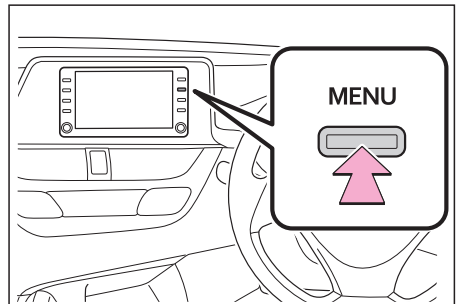

5. Select the "Apple CarPlay".

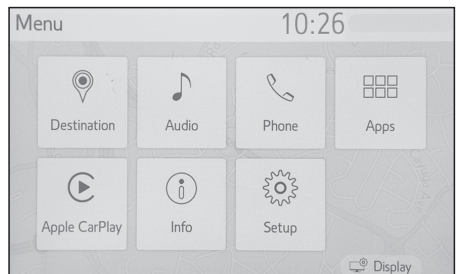

- Check the home screen of Apple CarPlay is displayed.

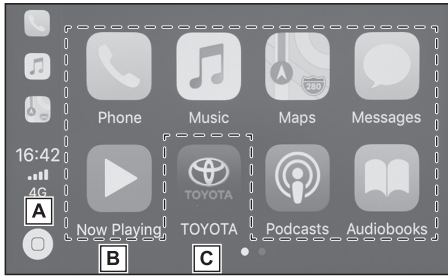

- A** Select to display the home screen of Apple CarPlay. Select and hold to activate Siri.
- B** Select to start the application. User can use any iPhone application supported by Apple CarPlay.
- C** Select to display the system screen.

Establishing an Android Auto connection

- Check the Android Auto application is installed to the device to be connected.
- Connect the device to the USB port. (→Section 4-1 in the Navigation & Multimedia System Owner’s Manual)
- Use a high quality USB cable that is less than 1.6 metres in length.
- Select “On” to enable the function.

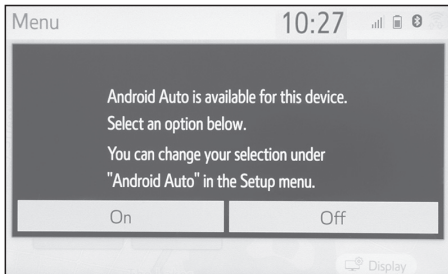

- A** “Off”: Select to not enable Android Auto. Android Auto will remain off until “Android Auto” of “Projection settings” on the general settings screen is turned on.

- Depending on the device connected, it may take approximately 3 to 6 seconds before the system returns to previous screen.
 - The screen may change to step 6 depending on the system.
- Press the “MENU” button.

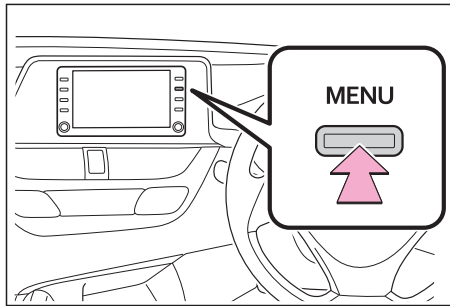

- Select the “Android Auto”.

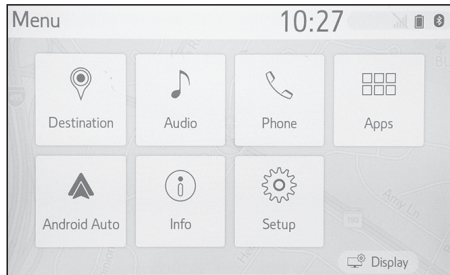

- Check the home screen of Android Auto is displayed.

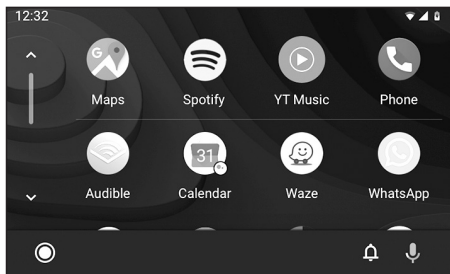

- A** Select to display the home screen of Android Auto.

- B** Select to start the application. User can use any Android application supported by Android Auto.
- C** Select to display the system screen.
- When an Apple CarPlay/Android Auto connection is established, the function of some system buttons will change.
 - When an Apple CarPlay/Android Auto connection is established, some system functions, such as the following, will be replaced by similar Apple CarPlay/Android Auto functions or will become unavailable:
 - iPod (Audio Playback)
 - USB audio/USB video
 - Bluetooth® audio
 - Bluetooth® phone (Apple CarPlay only)
 - Toyota App Suite
 - When an Android Auto connection is established while using Miracast®, Miracast® may become unavailable.
 - The guidance volume can be changed on the voice settings screen.
 - Apple CarPlay/Android Auto is an application developed by Apple Inc/Google LLC. Its functions and services may be terminated or changed without notice depending on the connected device's operation system, hardware and software, or due to changes in Apple CarPlay/Android Auto specifications.
 - For a list of the apps supported by Apple CarPlay or Android Auto, refer to their respective website.
 - While using these functions, vehicle and user information, such as location and vehicle speed, will be shared with the respective application publisher and the cellular service provider.
 - By downloading and using each application, you agree to their terms of use.
- Data for these functions is transmitted using the internet and may incur charges. For information about data transmission fees, contact your cellular service provider.
 - Depending on the application, certain functions, such as music playback, may be restricted.
 - As the applications for each function are provided by a third-party, they may be subject to change or discontinuation without notice. For details, refer to the website of the function.
 - If the vehicle's navigation system is being used for route guidance and a route is set using the Apple CarPlay/Android Auto Maps app, route guidance will be performed through Apple CarPlay/Android Auto. If the Apple CarPlay/Android Auto Maps app is being used for route guidance and a route is set using the vehicle's navigation system, route guidance will be performed by the vehicle's navigation system.
 - If the USB cable is disconnected, operation of Apple CarPlay/Android Auto will end. At this time, sound output will stop and change to the system screen.



Works with
Apple CarPlay

- Use of the Apple CarPlay logo means that a vehicle user interface meets Apple performance standards. Apple is not responsible for the operation of this vehicle or its compliance with safety and regulatory standards.

- Please note that the use of this product with iPhone or iPod may affect wireless performance.
- Apple CarPlay is a trademark of Apple Inc.

android auto

- Android and Android Auto are trademarks of Google LLC.



WARNING

- Do not connect smartphone or operate the controls while driving.



NOTICE

- Do not leave your smartphone in the vehicle. In particular, high temperatures inside the vehicle may damage the smartphone.
- Do not push down on or apply unnecessary pressure to the smartphone while it is connected as this may damage the smartphone or its terminal.
- Do not insert foreign objects into the port as this may damage the smartphone or its terminal.

Troubleshooting

If you are experiencing difficulties with Apple CarPlay/Android Auto, check the following table.

Symptom	Solution
An Apple CarPlay/Android Auto connection cannot be established.	<p>Check if the device supports Apple CarPlay/Android Auto.</p> <p>Check if Apple CarPlay/Android Auto is enabled on the connected device.</p> <p>Check if the Android Auto application is installed to the device to be connected.</p> <p>For details, refer to https://www.apple.com/ios/carplay/ https://www.android.com/auto/</p>
	<p>Check if “Apple CarPlay”/“Android Auto” of “Projection settings” on the general settings screen is set to on. (→P.20)</p>
	<p>Check if the USB cable being used is securely connected to the device and USB port.</p> <p>Try connecting the smartphone directly to the USB port in the vehicle, without using the hub.</p> <p>For Apple CarPlay: Check if the Lightning cable being used is certified by Apple and check if Siri is enabled.</p>
	<p>After checking all of the above, try to establish an Apple CarPlay/Android Auto connection. (→P.13)</p>
When an Apple CarPlay/Android Auto connection is established and a video is being played, the video is not displayed, but audio is output through the system.	<p>As the system is not designed to play video through Apple CarPlay/Android Auto, this is not a malfunction.</p>
Although an Apple CarPlay/Android Auto connection is established, audio is not output through the system.	<p>The system may be muted or the volume may be low. Increase the system volume.</p>

Symptom	Solution
<p>The Apple CarPlay/Android Auto screen has artefacts and/or audio from Apple CarPlay/Android Auto has noise.</p>	<p>Check if the USB cable being used to connect the device to the system is damaged. To check if the USB cable is damaged internally, connect the device to another system, such as a PC, and check if the device is recognised by the connected system. (The device should begin charging when connected.)</p> <p>After checking all of the above, try to establish an Apple CarPlay/Android Auto connection. (→P.13)</p>
<p>The map display of the Apple CarPlay Maps app cannot be enlarged or contracted with pinch multi-touch gestures.</p>	<p>As the Apple CarPlay Maps app is not compatible with pinch multi-touch gestures, this is not a malfunction.</p>
<p>During Apple CarPlay music application (Apple Music, Spotify, etc.) playback, if the iPhone is operated to start and play audio from an application that is not compatible with Apple CarPlay* and the onboard device volume is changed, the audio of the incompatible application stops and the system resumes playback of the original music application.</p>	<p>This operation is performed according to the specification of the onboard device, this is not a malfunction.</p>
<p>After an interruption, audio (such as navigation route guidance) is played from an application that is not compatible with Apple CarPlay while the onboard device is playing audio (FM/AM, CD, etc.), the system does not resume playback of the original audio (FM/AM, CD, etc.).</p>	<p>This operation is performed according to the specification of the onboard device, this is not a malfunction. Manually change the audio source yourself.</p> <p>Or, do not use applications that are not compatible with Apple CarPlay*. Some navigation applications are compatible from iOS 12, update to the latest iOS and application versions.</p>

Symptom	Solution
When using Apple CarPlay, route guidance arrows and turn by turn navigation are not displayed on the multi-information display and system display. When using Android Auto, turn by turn navigation is not displayed on the multi-information display and system display.	This is not a malfunction as display of these items is not possible with this function.
When using Android Auto, hands-free call audio cannot be heard from the vehicle's speakers.	Disconnect the phone from the USB cable and check if hands-free call audio can be heard using the hands-free system.
	Connect the phone to the system using Android Auto, turn up the volume on the system and check if hands-free call audio can be heard. Check if other sounds can be heard from the vehicle's speakers.

*: Applications not compatible with Apple CarPlay are applications installed on the iPhone that are not displayed on the Apple CarPlay screen application list. (such as visual voicemail)

General settings

Settings are available for clock, operation sounds, etc.

Displaying the general settings screen

1. Press the “MENU” button.

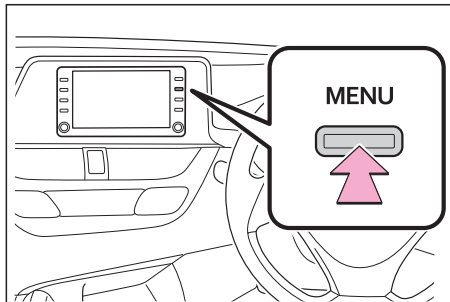

2. Select “Setup”.
 - If the general settings screen is not displayed, select “General”.
3. Select the desired items to be set.

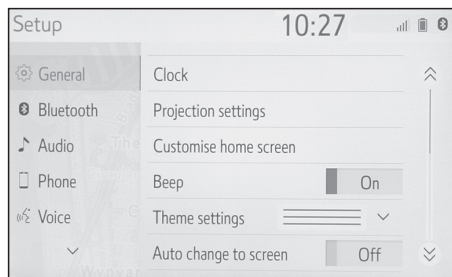

Projection settings

1. Display the general settings screen.
2. Select “Projection settings”.
3. Select the desired items to be set.

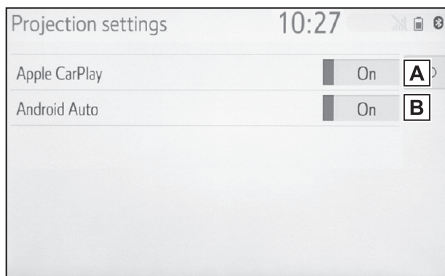

- A** Select to turn Apple CarPlay connection establishment on/off when a compatible iPhone is connected to the system via USB.

Depending on the system, this setting cannot be changed when a device is connected to the system via USB. Disconnect the device before attempting to change the setting.

- B** Select to turn Android Auto connection establishment on/off when a compatible device is connected to the system via USB.

Depending on the system, this setting cannot be changed when a device is connected to the system via USB. Disconnect the device before attempting to change the setting.

Quick reference	22
Functional overview	22
Selecting an audio source	23
USB memory	24
Overview	24
iPod/iPhone (Apple CarPlay)	25
Overview	25
Android Auto	26
Overview	26
Bluetooth audio	27
Overview	27
Steering switches	28
Steering switch operation	28

Quick reference

Functional overview

The audio control screen can be reached by the following methods:

- ▶ From the “AUDIO” button
 1. Press the “AUDIO” button.
- ▶ From the “MENU” button
 1. Press the “MENU” button, then select “Audio”.

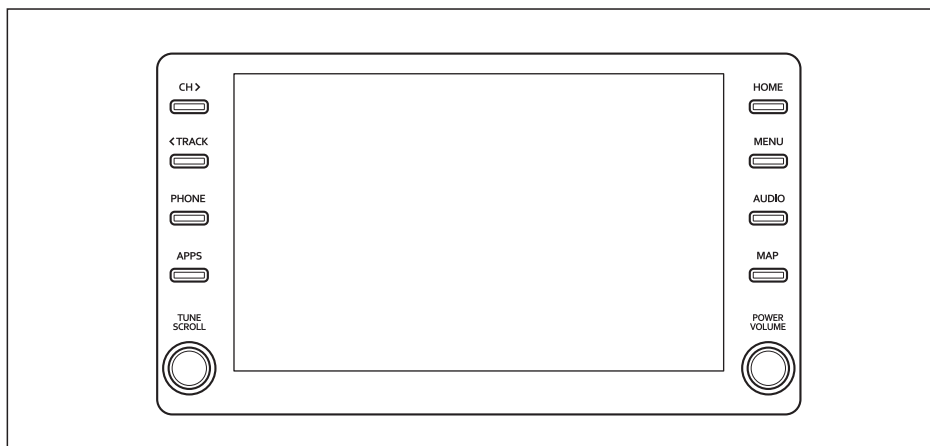

- Using the radio (→Section 4-2 in the Navigation & Multimedia System Owner's Manual)
- Playing a USB memory (→Section 4-3 in the Navigation & Multimedia System Owner's Manual)
- Playing an iPod/iPhone (Apple CarPlay) (→P.25)
- Using the Android Auto (→P.26)
- Playing a Bluetooth® device (→P.27)
- Using the Miracast® (→Section 4-3 in the Navigation & Multimedia System Owner's Manual)
- Using the steering wheel audio switches (→P.28)
- Audio system settings (→Section 4-5 in the Navigation & Multimedia System Owner's Manual)

Selecting an audio source

1. Press the “AUDIO” button.

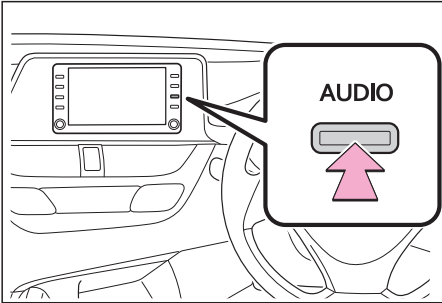

2. Select “Source” or press “AUDIO” button again.
3. Select the desired source.

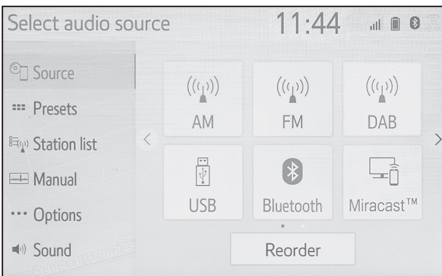

- Dimmed screen buttons cannot be operated.
- When there are two pages, select < or > to change the page.
- When an Apple CarPlay/Android Auto connection is established, some system functions, such as the following, will be replaced by similar Apple CarPlay/Android Auto functions or will become unavailable:
 - iPod (Audio Playback)
 - USB audio/USB video
 - Bluetooth® audio
 - Toyota App Suite

USB memory

Overview

The USB memory operation screen can be reached by the following methods (→P.23):

- Connecting a USB memory. (→Section 4-1 in the Navigation & Multimedia System Owner's Manual)
- When an Apple CarPlay/Android Auto connection is established, this function will be unavailable.

iPod/iPhone (Apple Car-Play)

Overview

The iPod/iPhone operation screen can be reached by the following methods (→P.23):

- Connecting an iPod/iPhone. (→Section 4-1 in the Navigation & Multimedia System Owner's Manual)
- When an Android Auto connection is established, this function will be unavailable.

Control screen

- ▶ An Apple CarPlay connection is not established.

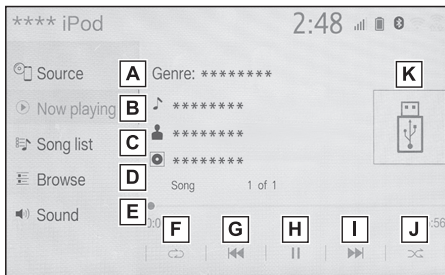

- ▶ An Apple CarPlay connection is established.

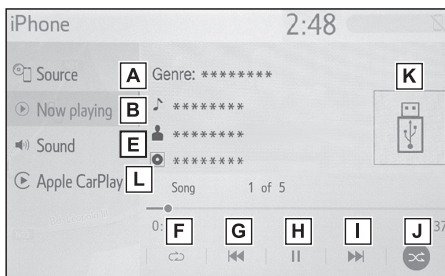

- A** Select to display the audio source selection screen.
- B** Select to return to the top screen.

- C** Select to display a song list screen.
- D** Select to display the play mode selection screen.
- E** Select to display the sound setting screen. (→Section 4-1 in the Navigation & Multimedia System Owner's Manual)
- F** Select to set repeat playback. (→Section 4-3 in the Navigation & Multimedia System Owner's Manual)
- G** Select to change the track. Select and hold to fast rewind.
- H** Select to play/pause.
- I** Select to change the track. Select and hold to fast forward.
- J** Select to set random playback. (→Section 4-3 in the Navigation & Multimedia System Owner's Manual)
- K** Displays cover art.
- L** Select to display the audio control screen of Apple CarPlay.

Android Auto

Overview

The Android Auto operation screen can be reached by the following methods (→P.23):

- Connecting an Android Auto device. (→Section 4-1 in the Navigation & Multimedia System Owner's Manual)
- When an Apple CarPlay connection is established, this function will be unavailable.

Control screen

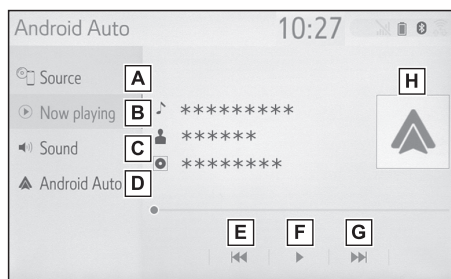

- A** Select to display the audio source selection screen.
- B** Select to return to the top screen.
- C** Select to display the sound setting screen. (→Section 4-1 in the Navigation & Multimedia System Owner's Manual)
- D** Select to display the audio control screen of Android Audio.
- E** Select to change the track.
- F** Select to play/pause.
- G** Select to change the track.
- H** Displays cover art.

Control panel

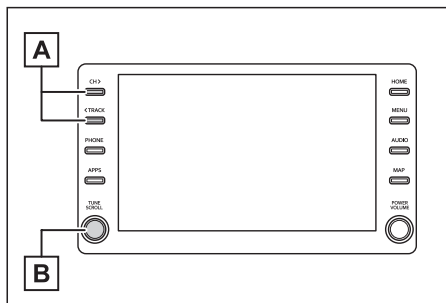

- A** Press to change the track.
- B** Turn to change the track.

! WARNING

- Do not connect smartphone or operate the controls while driving.

! NOTICE

- Do not leave your smartphone in the vehicle. In particular, high temperatures inside the vehicle may damage the smartphone.
- Do not push down on or apply unnecessary pressure to the smartphone while it is connected as this may damage the smartphone or its terminal.
- Do not insert foreign objects into the port as this may damage the smartphone or its terminal.

Bluetooth audio

The Bluetooth® audio system enables users to enjoy listening to music that is played on a portable player on the vehicle speakers via wireless communication.

This audio/visual system supports Bluetooth®, a wireless data system capable of playing portable audio music without cables. If your device does not support Bluetooth®, the Bluetooth® audio system will not function.

Overview

The Bluetooth® audio operation screen can be reached by the following methods (→P.23):

- Connecting a Bluetooth® audio device. (→Section 4-1 in the Navigation & Multimedia System Owner's Manual)
- Depending on the type of portable player connected, some functions may not be available and/or the screen may look differently than shown in this manual.
- When an Apple CarPlay/Android Auto connection is established, Bluetooth® audio will be suspended and become unavailable.

Control screen

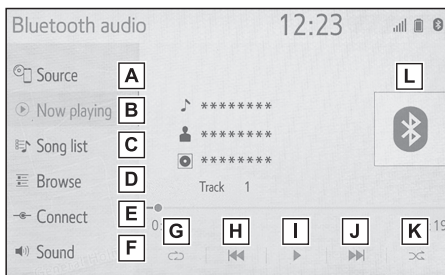

- A** Select to display the audio source selection screen.

- B** Select to return to the top screen.
- C** Select to display a song list screen.
- D** Select to display the play mode selection screen.
- E** Select to display the portable device connection screen. (→Section 4-3 in the Navigation & Multimedia System Owner's Manual)
- F** Select to display the sound setting screen. (→Section 4-1 in the Navigation & Multimedia System Owner's Manual)
- G** Select to set repeat playback. (→Section 4-3 in the Navigation & Multimedia System Owner's Manual)
- H** Select to change the track . Select and hold to fast rewind.
- I** Select to play/pause.
- J** Select to change the track. Select and hold to fast forward.
- K** Select to set random playback. (→Section 4-3 in the Navigation & Multimedia System Owner's Manual)
- L** Displays cover art.

Steering switches

Steering switch operation

Some parts of the audio/visual system can be adjusted using the switches on the steering wheel.

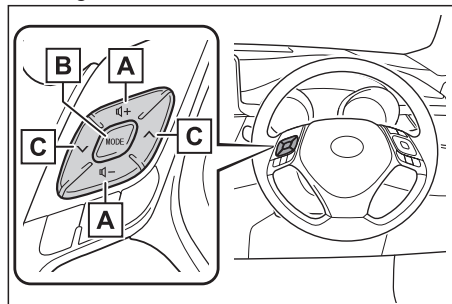

- A** Volume control switch
- B** "MODE" switch
- C** Seek switch

■ Volume control switch

- Press: Volume up/down
- Press and hold (0.8 sec. or more): Volume up/down continuously

■ "MODE" switch

- ▶ AM/FM/DAB
 - Press: Change audio modes
 - Press and hold (0.8 sec. or more): Mute (Press and hold again to resume the sound.)
- ▶ USB, iPod/iPhone, Bluetooth® audio, Android Auto
 - Press: Change audio modes
 - Press and hold (0.8 sec. or more): Pause (Press and hold again to resume the play mode.)
- ▶ Miracast®
 - Press: Change audio modes

■ Seek switch

- ▶ AM/FM
 - Press: Preset stations up/down (Presets screen)
Station up/down (Station list screen)
Seek up/down (Manual tuning screen)
 - Press and hold (0.8 sec. or more):
Seek up/down continuously while the switch is being pressed (Manual tuning screen)
- ▶ DAB
 - Press:
Preset services/stations up/down (Presets screen)
Service/station up/down (Service/station list screen)
Seek up/down (Manual tuning screen)
 - Press and hold (0.8 sec. or more):
Seek up/down continuously while the switch is being pressed (Manual tuning screen)
- ▶ USB, iPod/iPhone, Bluetooth® audio
 - Press: Track/file up/down
 - Press and hold (0.8 sec. or more): Fast forward/rewind
- ▶ Android Auto
 - Press: Track/file up/down

- Speech command system 30**
 - Using speech command system30
- Command list 31**
 - Command list overview31
 - Command list.31

Speech command system

The speech command system enables the radio, phone dialing, etc. to be operated using speech commands.

Refer to the command list for samples of speech commands. (→P.31)

Using speech command system

■ Steering switch

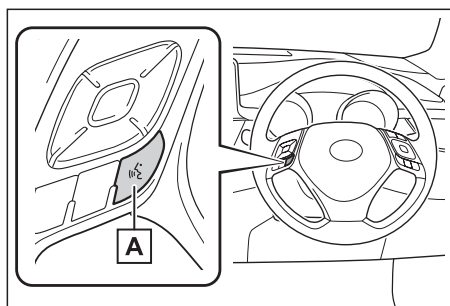

A Talk switch

- Press the talk switch to start the speech command system.
- To cancel speech command, press and hold the talk switch.

When an Apple CarPlay/Android Auto connection is established:

- Press and hold the talk switch to start Siri/Google Assistant. To cancel Siri/Google Assistant, press the talk switch.

■ Microphone

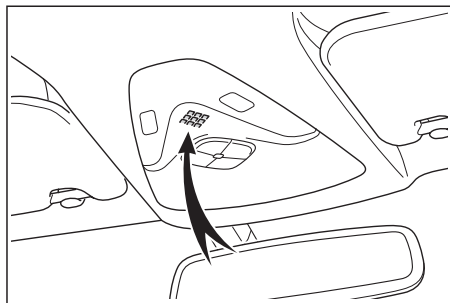

- It is unnecessary to speak directly into the microphone when giving a command.
- Wait for the confirmation beep before speaking a command.
- Speech commands may not be recognised if:
 - Spoken too quickly.
 - Spoken at a low or high volume.
 - The roof or windows are open.
 - Passengers are talking while speech commands are spoken.
 - The fan speed of the air conditioning system is set at high.
 - The air conditioning vents are turned towards the microphone.
- In the following conditions, the system may not recognise the command properly and using speech commands may not be possible:
 - The command is incorrect or unclear. Note that certain words, accents or speech patterns may be difficult for the system to recognise.
 - There is excessive background noise, such as wind noise.
- This system may not operate immediately after the engine switch <power switch> is turned to ACC or ON.

⚠ NOTICE

Do not touch and put a sharp object to the microphone. It may cause failure.

Command list

*: This function cannot be used for vehicles without a talk switch on the steering wheel.

Command list overview

Recognisable speech commands and their actions are shown below.

- Frequently used commands are listed in the following tables.
- For devices that are not installed to the vehicle, commands relating to that device may not be displayed on the screen. Also, depending on other conditions, such as compatibility, some commands may not be displayed on the screen.
- The functions available may vary according to the system installed.
- When an Apple CarPlay/Android Auto connection is established, some commands will become unavailable.

Command list

■ Common

Command	Action
"Go back"	Returns to the previous screen
"Help"	Prompts voice guidance to offer examples of commands or operation methods
"Cancel"	Cancels the speech command system
"Start over"	Returns to top menu screen
"Pause"	Temporarily pauses a voice session until it is resumed by pressing the talk switch again

■ Top menu

Command	Action
"Go to <function>"	Displays the command list of the selected function
"More hints"	Displays more commonly used commands

■ Audio

Command	Action
“Play artist <artist name>” ^{*1}	Plays tracks from the selected artist
“Play album <album name>” ^{*1}	Plays tracks from the selected album
“Play playlist <playlist name>” ^{*1, 2}	Plays tracks from the selected playlist
“Play song <song>” ^{*1}	Plays the selected track
“Auxiliary”	Selects AUX audio mode
“USB”	Selects USB audio mode that is connected first
“USB2”	Selects USB audio mode that is connected last
“iPod”	Selects iPod audio mode that is connected first
“iPod2”	Selects iPod audio mode that is connected last
“Bluetooth audio”	Selects Bluetooth® audio mode
“Android Auto” ^{*3}	Selects Android Auto music

*1: The audio device must be connected via a USB cable to use the functionality

*2: Available only for iPod/iPhone

*3: Available when an Android Auto connection is established.

Phone basics 34
Using the phone switch /
microphone34

Phone basics

The hands-free system enables calls to be made and received without having to take your hands off the steering wheel.

This system supports Bluetooth®.

Bluetooth® is a wireless data system that enables cellular phones to be used without being connected by a cable or placed in a cradle.

The operating procedure of the phone is explained here.

When an Apple CarPlay connection is established, phone functions will be performed by Apple CarPlay instead of the hands-free system.

Using the phone switch / microphone

■ Steering switch

By pressing the phone switch, a call can be received or ended without taking your hands off the steering wheel.

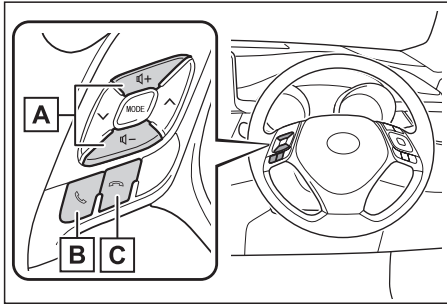

A Volume control switch.

Press to adjust the volume.

B Off hook switch.

Press to start talking.

If the switch is pressed when an Apple CarPlay/Android Auto connection is established, the Apple CarPlay/Android Auto phone application will be displayed on the system screen.

C On hook switch.

Press to end talking/dialing.

Toyota App Suite service	36
Toyota App Suite	36
Before using the function	37
Preparation before using Toyota App Suite	37
Toyota App Suite	38
Using Toyota App Suite	38
Updating an application	38
If a message appears on the screen	39
Linking Toyota App Suite and navigation local function	40
Toyota App Suite settings.	42
Displaying the Toyota App Suite settings screen.	42
Toyota App Suite settings screen	42
Toyota App Suite settings	42
Displaying the Toyota App Suite settings screen.	42
Toyota App Suite settings screen	42

Toyota App Suite service

Toyota App Suite enables applicable apps installed on a smartphone to be displayed on and operated from the screen via a Bluetooth®.

A few settings must be performed before Toyota App Suite can be used. (→P.37)

Toyota App Suite

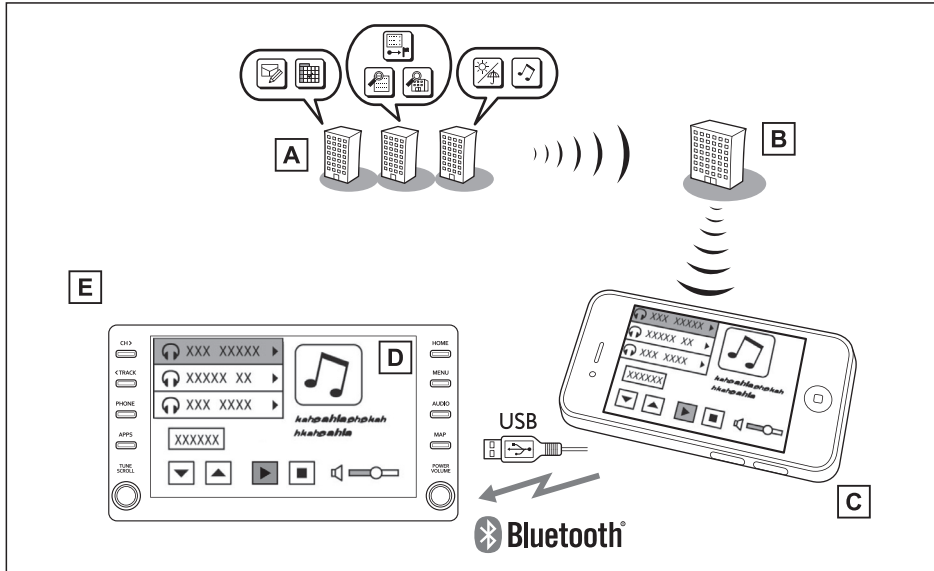

- A** Contents provider.
Provides contents to the application server.
- B** Application server.
Provides applications to the navigation system via a smartphone.
- C** Smartphone*.
Using the Toyota App Suite application, communication is relayed between the system, application server and contents provider.
A smartphone cannot be operated while communicating.
- D** Applications.
Displays and sounds the usable contents from the content providers via a smart-phone on the application player.
- E** Navigation system.
Contents received, via a smartphone, from the contents provider servers are displayed on the navigation screen. The navigation system is equipped with an application player to run applications.

*: For known compatible phones, refer to <https://www.toyota.com.au/> or <https://www.toyota.co.nz>.

Before using the function

■ Availability of service

- Toyota App Suite is available in Australia and New Zealand.
- Data usage fees may apply while using Toyota App Suite function. Confirm data usage fees before using this function.
- For details regarding operation of the Toyota App Suite and the applications, refer to <https://www.toyota.com.au/> or <https://www.toyota.co.nz>.
- Availability of functions of the Toyota App Suite service is dependent on network reception level.

■ Initialising personal data

The personal data used in applications can be reset. (→Section 2-4 in the Navigation & Multimedia System Owner's Manual)

- The following personal data can be deleted and returned to their default settings:
 - Downloaded contents
 - Radio stations that were listened to
 - Entered history
- Once initialised, data will be erased. Pay close attention when initialising the data.

Preparation before using Toyota App Suite

■ Settings required to use Toyota App Suite

Perform the settings in the following order.

1. Download the Toyota App Suite application to your smartphone or the system.
2. Register a Bluetooth® phone with the hands-free system. (→Section 2-2 in the Navigation & Multimedia System Owner's Manual)

- Applications can only be used when the Toyota App Suite application has been downloaded to your smartphone or the system and the application is running.
- Toyota App Suite operational procedures can also be confirmed by visiting <https://www.toyota.com.au/> or <https://www.toyota.co.nz>.
- If a Toyota App Suite application is used while iPod audio/video is being played back, system operation may become unstable

Toyota App Suite

Toyota App Suite is a function that enables certain apps installed on a smartphone or the system to be displayed on and operated from the multimedia and navigation system screen. Before the Toyota App Suite can be used, some setup needs to be performed. (→P.37)

For details about the function and service provided by each application, refer to <https://www.toyota.com.au/> or <https://www.toyota.co.nz>

Using Toyota App Suite

- ▶ From the “MENU” button
- 1. Press the “MENU” button.

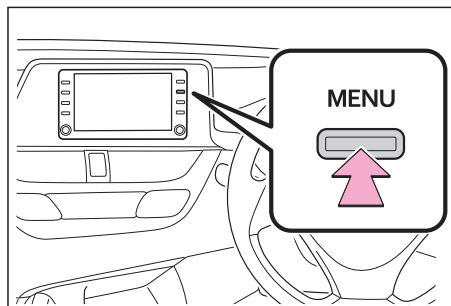

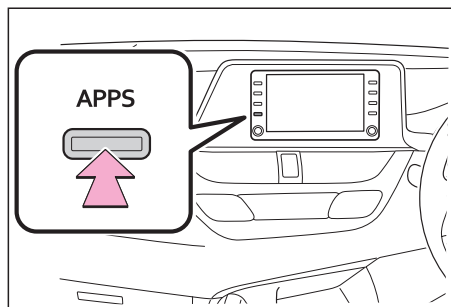

- 2. Select “Apps”.

- ▶ From the “APPS” button
- 1. Press the “APPS”.



- 2. Select “Apps”.

- If a specific application screen is displayed, select “Apps” again.
- 3. Select the desired application screen button.
- : Select to activate an application.
- “Update”: Select to update the application, see below.
-  2: Displays the number of new notifications for the application.

Updating an application

When the Toyota App Suite is activated, an application may need to be updated. By updating the application, it can be kept to the latest version. To update the application, it is necessary to download the updated data and install it.

■ Downloading update

If an update is available, “Update” can be selected.

1. Select “Update” on the application screen.
2. Check that downloading starts.
 - “Download in background”: Select to operate other functions while downloading.
 - “Cancel”: Select to cancel updating.
3. Check that downloading is complete.
 - “Later”: Select to install later. When this screen button is selected, the screen will return to the last displayed screen. To install the update data see below.
 - “Show details”: Select to display detailed information on the update data.
 - “Install”: Select to install the update data. Follow the steps “Installing the update data” from step 2.

■ Installing the update data

After the downloading is complete, “Update” will be changed to “Install”.

1. Select “Install” on the application screen.
2. Select “Continue”.
 - “Later”: Select to postpone the installation of the update data and go back to the previous screen.
3. Check that installing is started.
 - “Install in background”: Select to operate other functions while installing.
4. Select “OK” after the installing is complete.
 - The Toyota App Suite function cannot be operated while installing.

If a message appears on the screen

When problems occur with starting the application player, a message will appear on the screen. Referring to the table below, identify the problem and take the suggested corrective action.

Message	Solution
“Installation could not be completed. Try again.”	Application download can be attempted again by changing to the application screen.
<ul style="list-style-type: none"> ● “When it is safe and legal to do so, ensure your Toyota App Suite application is running and logged in on your phone.” ● “Download could not be completed. Some Toyota App Suite functions may not work as expected. Reinitiate the download process.” ● “Application download could not be completed. Try again later.” 	<p>The Toyota App Suite application cannot be connected to Bluetooth® SPP.</p> <p>Refer to https://www.toyota.com.au/ or https://www.toyota.co.nz to confirm if the phone is Bluetooth® SPP compatible or not, and then activate the Toyota App Suite application.</p> <p>Please ensure your Toyota App Suite application is running and logged in on your phone while vehicle is not moving.</p>

Linking Toyota App Suite and navigation local function

The navigation system's setting a destination and making a handsfree call can be performed via Toyota App Suite. For details about the function and service of each application, refer to <https://www.toyota.com.au/> or <https://www.toyota.co.nz>.

■ From the "MAP" button

1. Press the "MAP" button.

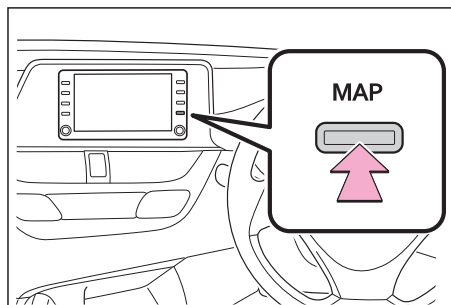

2. Select .
3. Select "Web search".
4. Check that the "Web search" screen is displayed.

■ From the "MENU" button

1. Press the "MENU" button.

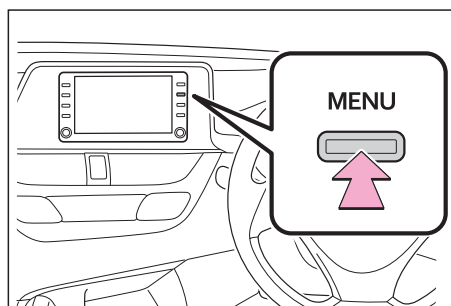

2. Select "Destination".
3. Select "Web search".
4. Check the "Web search" screen is displayed.

Setting a destination using Toyota App Suite

Locations that were searched using Toyota App Suite can be set as a destination.

1. Display the "Web search" screen, see above.
 2. Select the desired application button to search.
 3. Enter a search term, and select "Go".
 4. Select "Map".
 5. Select "Go directly".
 6. Select "OK" to start guidance.
- For the operation of the route guidance screen and the function of each screen button. (→Section 3-2 in the Navigation & Multimedia System Owner's Manual)

Making a phone call using Toyota App Suite

Phone calls can be made to locations which were searched using Toyota App Suite.

1. Display the "Web search" screen, see above.
 2. Select the desired application button to search.
 3. Enter a search term, and select "Go".
 4. Select a switch for making a call.
 5. Select "Yes".
"Cancel": Select to cancel making a phone call.
 6. Check the call screen is displayed.
- For phone operation and the function of each screen button. (→Section 7-1 in the Navigation & Multimedia System Owner's Manual)

Entering keyword operation

A keyword can be entered to an application by the software keyboard.

For details about the functions and services provided by each application, refer to <https://www.toyota.com.au/> or <https://www.toyota.co.nz>.

- The keyboard layout can be changed.
(→Section 2-4 in the Navigation & Multimedia System Owner's Manual)
- **Entering a keyword using the software keyboard**
 1. Display the application screen.
(→P.38)
 2. Select the desired application screen button.
 3. Select the character entering space.
 4. Enter a search terms, and then select "OK".
 5. Entering characters will be reflected on the character entering space.
- For details on operating the keyboard.
(→Section 2-1 in the Navigation & Multimedia System Owner's Manual)

Toyota App Suite settings

The settings of Toyota App Suite can be changed.

Displaying the Toyota App Suite settings screen

1. Press the "MENU" button.

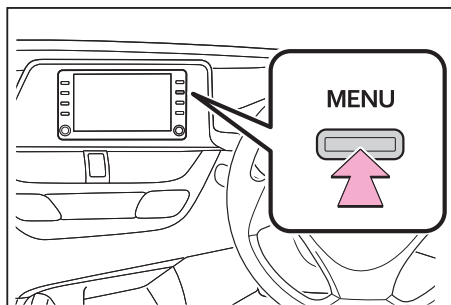

2. Select "Setup".
3. Select "Toyota App Suite".
4. Select the items to be set.

Toyota App Suite settings screen

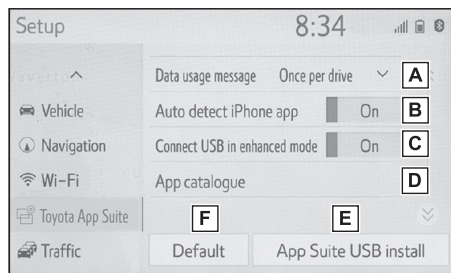

- A** Select to set the pop up reminder for smartphone data usage.
- B** Select to detect iPhone app automatically on/off.

- C** Select to turn on/off the enhanced USB connection mode.
 - When an iPhone is connected while this setting is set to "On", communication with devices connected to other USB ports may not be possible. Also, depending on the device, charging may not be possible.
- D** Select to configure the Apps menu layout (e.g. app order, which applications are activated, etc.).
- E** Select to install the Apps via a USB memory device. For details, contact your Toyota dealer.
- F** Select to reset all setup items.

**Software update terms
of use**



By proceeding with the update, you agree and acknowledge that:

- (a) Apple CarPlay* is a feature of iOS provided by Apple Inc., and is subject to Apple's* terms of use, available at <https://www.apple.com/ios/carplay/>. In providing Apple CarPlay*, Apple* may collect your personal information and user and vehicle information, such as location and vehicle speed. Your personal information will be collected and handled in accordance with Apple's* privacy policy, available at <https://www.apple.com/au/legal/privacy/en-ww/>;
- (b) Android Auto™ ^ is provided by Google LLC, and is subject to Google's^ terms of use, available at <https://www.android.com/auto/>. In providing Android Auto^, Google^ may collect your personal information and user and vehicle information, such as location and vehicle speed. Your personal information will be collected and handled in accordance with Google's privacy policy available at <https://policies.google.com/?hl=en&gl=au>;
- (c) the Toyota App Suite, also known as SmartDeviceLink™ is provided by SmartDeviceLink Consortium, Inc., and is subject to SmartDeviceLink's terms of use <https://smartdevicelink.com/licenses/>. In providing SmartDeviceLink, the SmartDeviceLink Consortium Inc may collect your personal information and user and vehicle information, such as location and vehicle speed. Your personal information will be collected and handled in accordance with the SmartDevice Link Consortium Inc's privacy policy available at accordance with its privacy policy available at <https://smartdevicelink.com/privacy/>;
- (d) third party fees may apply to access and use some of the features available on Apple CarPlay*, Android Auto^ and SmartDeviceLink (collectively, the Services). For further information, visit <http://www.apple.com/ios/carplay/>, <https://www.android.com/auto/> or <https://smartdevicelink.com/licenses/>;
- (e) access to and use of the Services requires a compatible device, GPS signal and sufficient mobile data and. Mobile usage is at your cost. For information about data transmission fees, contact your mobile phone service provider. For information about devices compatible with Apple Carplay or Android Auto, refer to www.apple.com/ios/carplay or www.andorid.com/auto;
- (f) in some States or Territories some or all of the functions provided by the Services are not permitted while driving. Please check your local road rules before using these functions. Please drive safely;
- (g) some functions, including iPod* (Audio Playback), USB audio / USB video, Bluetooth® audio, Bluetooth® phone and the Toyota App Suite, may not be available. Personal data or other information (Data) stored on your vehicle's head unit may be lost or destroyed. Toyota Motor Corporation Australia Limited (TMCA) is not responsible for any loss of Data;

*: Apple, iPod and Apple Carplay are trademarks of Apple, Inc. registered in the U.S. and other countries.

^ Google and Android Auto are trademarks of Google LLC.

Bluetooth®, is a registered trademark of Bluetooth SIG, Inc.

- (h) the terms of TMCA's privacy policy from time to time, available at www.toyota.com.au/privacy (Privacy Policy) are incorporated into these terms of use by reference. If you provide or make available any personal information or sensitive information of a third party to TMCA you warrant that you have obtained the third party's consent to disclose their information to TMCA for collection, use and transfer in accordance with the terms of the Privacy Policy. Your information may be collected, held, used and shared within the OneToyota network* to provide you an integrated guest experience across the network, and will be handled in accordance with the privacy policies of those OneToyota organisations that deal with you (as applicable) available at www.toyota.com.au/privacy;
- * OneToyota comprises: Toyota, authorised Toyota dealers in Australia, Toyota Finance Australia Limited, Aioi Nissay Dowa Insurance Company Australia Pty Ltd trading as Toyota Insurance, and Toyota Western Australia (comprising Prestige Motors Pty Ltd as trustee for the Prestige Toyota Unit Trust and Eastpoint Pty Ltd);
- (i) use of the Services is at your sole risk and that the entire risk as to satisfactory quality, performance, accuracy and effort is with you. To the maximum extent permitted by applicable law, the Services are provided on an "as is" and "as available" basis, with all faults and without warranty of any kind and
- TMCA hereby disclaims all warranties, guarantees and conditions with respect to the Services;
- (j) TMCA does not warrant against interference with your enjoyment of the Services, that the Services will meet your requirements, that the Services will be uninterrupted or error-free, that defects (if any) in the Services will be corrected or that information provided via the Services is accurate, complete, current or suitable to your purposes. No oral or written information or advice given by TMCA or its authorised representative shall create a warranty;
- (k) TMCA, and its licensors, reserve the right to change, suspend, remove, terminate or disable access to any Services at any time without notice. In no event will TMCA be liable for the removal of or disabling of access to any such Services;
- (l) certain Services may display, include or make available content, data, information, applications or materials from third parties (Third Party Materials) or provide links to certain third party web sites. By using the Services, you acknowledge and agree that TMCA is not responsible for examining or evaluating the content, accuracy, completeness, timeliness, validity, copyright compliance, legality, decency, quality or any other aspect of such Third Party Materials or web sites. TMCA does not warrant or endorse and does not assume and will not have any liability or responsibility to you or any other person for any third-party

*: Apple, iPod and Apple Carplay are trademarks of Apple, Inc. registered in the U.S. and other countries.

^ Google and Android Auto are trademarks of Google LLC.

Bluetooth® is a registered trademark of Bluetooth SIG, Inc.

Services, Third Party Materials or web sites, or for any other materials, products, or services of third parties;

- (m) TMCA expressly limits its liability for breach of a condition or warranty implied or a consumer guarantee imposed by virtue of any legislation to the following remedies (the choice of which is to be at TMCA's sole discretion):
- (i) in the case of goods, the replacement of the goods or supply of equivalent goods, the repair of the goods, the payment of the costs of replacing the goods or of acquiring equivalent goods or the payment of the costs of having the goods repaired; and
 - (ii) in the case of services, the supply of the services again or the payment of the cost of having the services supplied again.
- (n) to the extent permitted by law, in no event shall TMCA be liable for any loss or damage (including direct, incidental, special, indirect or consequential damages, loss of profits, loss of data or business interruption costs) arising out of or related to your use or inability to use the Services, however caused, regardless of the theory of liability (contract, tort, including negligence or otherwise) and even if TMCA has been advised of the possibility of such damages. The foregoing limitations will apply even if the above stated remedy fails of its essential purpose;

- (o) TMCA may assign or transfer its rights and obligations under these terms of use to another organisation, but this will not affect your rights or TMCA's obligations under these terms of use;
- (p) these terms of use are governed by the laws of Victoria, Australia. The parties submit to the exclusive jurisdiction of its courts and courts of appeal from them. The parties will not object to the exercise of jurisdiction of those courts on any basis.

If you have any questions, please refer to your Owner's Manual, contact your dealer, or call us on 1800 869 682.

Last updated on 02 October 2019

*: Apple, iPod and Apple Carplay are trademarks of Apple, Inc. registered in the U.S. and other countries.

^ Google and Android Auto are trademarks of Google LLC.

Bluetooth®, is a registered trademark of Bluetooth SIG, Inc.

Alphabetical index



A

Android Auto **26**
 Overview 26

Apple CarPlay/Android Auto **13**
 Establishing an Android Auto
 connection 14
 Establishing an Apple CarPlay
 connection 13
 Troubleshooting 17

B

Bluetooth audio **27**
 Overview 27

Buttons overview **6**
 Operations of each part 6

C

Command list **31**
 Command list overview 31

G

General settings **20**
 Displaying the general settings
 screen 20
 Projection settings 20

I

iPod/iPhone (Apple CarPlay) **25**
 Overview 25

L

**Linking multi-information display
 and the system** **11**

M

“Menu” screen **8**
 “Menu” screen operation 8

P

Phone basics **34**
 Using the phone switch/microphone ... 34

Q

Quick reference **22**
 Functional overview 22
 Selecting an audio source 23

R

**Registering/Connecting a
 Bluetooth® device** **12**

S

Speech command system **30**
 Using speech command system 30

Steering switches **28**
 Steering switch operation 28

T

Touch screen **10**
 Touch screen gestures 10

Toyota App Suite service **36**
 Before using the function 37
 If a message appears on the screen ... 39
 Linking Toyota App Suite and
 navigation local function 40
 Preparation before using Toyota
 App Suite 37
 Toyota App Suite 36
 Toyota App Suite settings 42
 Updating an application 38
 Using Toyota App Suite 38

U

USB memory **24**
 Overview 24



Part Number: TSO1910
Issue: 1910-01